

06/2019

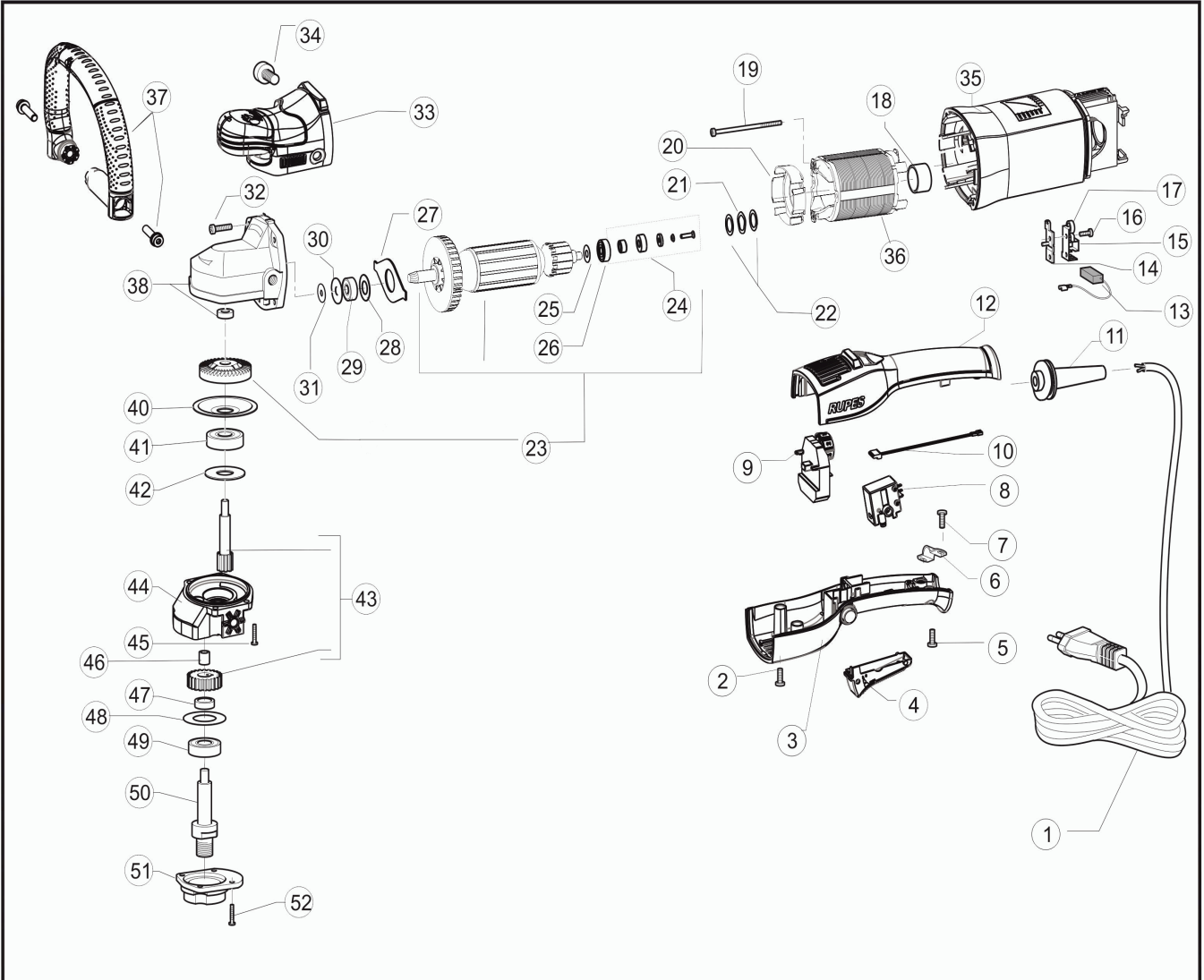

RUPES

LUCIDATRICE ANGOLARE ROTATIVA
 ROTARY ANGULAR POLISHER

LH19E

ID	ITEM	DESCRIPTION
001	9C2X1,0N489FOR	CABLE 2X1 (plug Schuko d4,8) mt.9 H07RN-F FLEX
001	9C2X1,0NGB9FOR	CABLE 2X1 (plug UK) with fork H07RN-F CENTRAL METAL PLUG mt.9
001	9C2X1,0NAU9FOR	CABLE 2X1 (plug Australia) H07RN-F mt.9
001	9C2X1,0R409FOR	CABLE 2X1 (plug D4) H07RN-F mt.9 with fork (only Swiss)
001	9C2X1,0RCN9FOR	CABLE 2x1 (CCC) (plug China) mt.9 with fork
001	9C2X0,8VUS9	CAVO 2x18AWG spina AMERICANA polarizzata R21 9mt.
001	9C2X1,25VJA9FOR	CABLE 2x1,25 (plug JAPAN) mt.9 with fork
002	9.552	SCREW 3,9x25 (7x1") T.C.C.
003	44.374/C	COMPLETE LOWER HANDLE
004	38.374/C	SWITCH BUTTON
005	9.660	SCREW 3,9x16 (7x5/8") T.C.C.
006	442.55	CABLE CLAMP
007	9.660	SCREW 3,9x16 (7x5/8") T.C.C.
008	45.372	GRADUAL SWITCH
009	400.374/C	ELECTRONIC MODULE 50Hz LH19E
009	400.374/60HZ/C	ELECTRONIC MODULE 60Hz LH19E
010	408.374/C	SWITCH WIRING
011	42.290	CABLE SLEEVE SS31TE
012	441.374/C	IMPUGNATURA GOMMATA SUPERIORE COMPLETA
013	47.105/10	BLISTER WITH 10 PC. BRUSHES BA215
014	462.105	BRUSH HOLDER PLATE
015	46.105	BRUSH HOLDER BA215-LH18ENS
016	9.551	SCREW 2,9x13 (4x1/2") T.C.C.
017	461.105	SPRING BRUSH HOLDER BA21 BURNISHED
018	268.105	BEARING CAP
019	9.787	SCREW 2,9x70 T.C.C.
020	73.322	AIR BULKHEAD
021	9.204	WASHER LMKAS 19 A .d18,8x13,2 s 0,2
022	9.306	STEEL WASHER d18 x 12,3 s 0,3
023	1.374/230S/C	ROTOR + GEAR CROWN (230V) LH19E
023	1.374/120S/C	ROTOR + GEAR CROWN (100-120V) LH19E
024	405.322/DX	GRUPPO MAGNETE LH19E
025	9.318	STEEL WASHER d15 x 6,1 s 0,15
026	9.14/10	BEARING 626ZZ
027	35.374/C	FLAT SPRING
028	9.298	STEEL WASHER d15 x 9,1 s 0,5
029	9.187/10	BEARING 629 2BRS R66 FA227
030	9.299	STEEL WASHER d18 x 9,1 s 0,15
031	9.120	SEEGER
032	9.679	SCREW 4,2x25 (8x1") T.C.C.
033	815.374/C	LH19E COMPLETE FRONT CAP
034	812.91	SCREW M8 x 15 T.C.IN NYLON A T.
035	31.374/C	BODY MOTOR LH19E
036	2.374/120S	STATOR (V.120) LK900
036	2.374/230S/C	STATOR (230V) LK900E
037	811.374/C	RUBBER D-LOOP HANDLE LH19E
038	32.326/C	GEAR BOX
040	35.105	FLANGE PLATE BA21-SL41
041	9.06/10	BEARING 6000 ZZ-C3
042	9.240	STEEL WASHER Ø25,9x21 s.015 BURNISHED
043	512.146/C	COIL SPRING GEAR CUP
044	321.374/C	GEAR BOX
045	9.637	SCREW M4 x 16 T.C.C. 8G BURNISHED
046	9.65	BUSH ROLLER
047	541.14	SPACER
048	9.385	CUP SPRING 36,6x20,4x0,5

ID	ITEM	DESCRIPTION
049	9.96/10	BEARING NSK 6001 DDUCM J EA3SZ
050	51.146	SPINDLE SHAFT
050	51.226	SPINDLE SHAFT 5/8"
051	322.146	BOX COVER
052	9.614	SCRE M4 x 12 T.C.C. d7,7 BRN 8.8